

Tools, Equipment & Materials



Fillauer®

In 1914, George Fillauer Sr. founded the Red Star Pharmacy in Chattanooga, Tennessee. In 1934, his son and fellow CPO, Carlton Fillauer expanded his father's business to establish Fillauer Orthopedic as an innovator in the orthotics and prosthetics industry. Today, the Fillauer Companies are headed by Karl Fillauer as Chairman and his son Michael as the CEO, since their inception, the Fillauer Companies have always been headed by CPO's, and have grown to be a globally renowned leader in the development, manufacturing, distribution and application of orthotic and prosthetic products. The expansion has mainly taken place by acquisitions of smaller manufacturing companies with a unique profile. Over the years we have become nine companies under the Fillauer umbrella and during the 100 year celebration in 2014 a decision was taken on how the company would be steered into the next century. Therefore a consolidation took place in 2015 where all the companies became Fillauer.

Fillauer Europe was founded as Centri in 1948. Located just outside Stockholm, Sweden, Centri joined the Fillauer Companies 2002. While Centri maintained the close, cooperative relationships it traditionally had with prosthetists in Scandinavia, as Fillauer Europe it has now become the European headquarters of Fillauer. With its extensive portfolio of products, Fillauer Europe is committed to working with prosthetists both in Europe, but also in other regions of the world in order to create only the best solutions for patients with all manner of prosthetic and orthotic needs. In addition, Fillauer Europe plays a lead Research & Development role within Fillauer. Fillauer Europe's products include upper and lower extremity prosthetics and the Dynamic Walk which has catapulted us to the forefront of the drop foot orthotics market. Our R&D department also works in partnership with many of Sweden's leading hospitals to develop innovative and high-tech machinery.



Index

Fillauer Product Warranty	6
Returns, Adjustments, and Credits	7
Catalog symbol legend	8

Trautman Carvers & Sanders

Trautman Arbor 5001	10
Trautman Double Drum Sander	11
Trautman Variable Speed Floor Carver	12
Trautman Single Speed Floor Carver	13
Trautman Tech Station	14
Dust Collector for Floor Carver	15
Dust Collection Hose Kit for 2100L	15
Air Attachment for Floor Carver	16
Accessory Holder for Floor Carver	16
Lift Assist Kit for Floor Carver	17
Trautman Variable Speed Bench Carver	18
Trautman Single Speed Bench Carver	18
Bench Carver Floor Stand	19
Accessory Holder for Bench Carver	19
Dust Collector for Bench Carver	19
Drill Attachments 1/2"-13 Thread	20
Cutters & Replacement Blades	20
Soft Foam Shaper	21
Shaft Foam Arbors	21
Urethane and Felt Arbors	22
Pneumatic Sand Drum	22
Sand Drum	22
Rubber Sand Cones	23
Tapered Felt Arbor/ Core	24
Expansion Arbors	25
Dual Purpose Expansion Arbors	26
Grinding Rasps	27
Router Adapters	27
Tycro Polishing Arbor	28
Trautman Coneiak Polishing Arbors	29

Trautman Vacuum Systems

Mobile Vacuum Unit	32
Vacuum Control Assembly	33
Portable Oilless Vacuum Pump	33
Holding Frames	34

Drape Forming Adapters	34
Trautman Vacuum Stations	35

PDQ Ovens

PDQ Rollabout Oven	37
PDQ BT-4 Infrared Oven	38
PDQ PO-2 Infrared Oven	39
PDQ Oven Fan Kit	40
Tongue Tray	40
PDQ Oven Gloves	40

Fabrication Equipment

Laminating Fixture LJ-100	42
Surgical Tubing	42
Vertical Fabricating Fixture, VFJ-100	43
Bar Contouring Device	44
Pipe Holding Fixtures	44
Prosthetic Bench Vise	45
Cable Swaging Tool	45
Drill Press Fixture	46
Universal Alignment Fixture	46
Stirrup Bender	46
Contouring Fork and Bench Receptacle	47
Joint Alignment Tool	47
Bending Irons	48
Contouring Irons	48
Spring Clamps	49
Yates Clamp	49
Scissors	49
Hex Screwdriver	50
Hex Keys	50
Torque Screwdriver	50
Torque Wrench	50
Scarpas Knife	51
Surgical Scalpel	51
Pin Wrench	51
Deburring Tool	52
Tube Cutter	52
Cutting Tool for 30 mm Tubes	52
Cast Cutter	53
Measuring Tapes	54

Cast Mandrels		Tape	75
	54	Silicone Glove	76
Surform™ Files		Release Film - sheet	76
	54	Silicone Bag	76
Transtibial Length Gauge	55		
Original AP-ML Gauge	55		
Universal AP-ML Gauge	55		
Transfemoral Length Gauge	56		
Goniometer	56		
Casting Fixture Gauge	56		
Rounded Blade Spatula			
	57		
Hot Mill Gloves	57		

Materials

Censoft	59
Cenpol	59
Thermo Foam 4E/ Firm Foam	60
Polypropylene	61
Thermoflex	62
Thermoflex with Silicone	62
Cleani-Stump Antiseptic Wipe	63
Isolation Bags	63
PVA Bags and Film	64
Alginate Impression Powder	64
PolyCar-C Sheets	65
Silicone	65
Transforming Silicone Putty	66
Polyester Stockinette - Lamination Tube	67
Elastic Stockinette Tube, 7% Lycra	67
Elastic Stockinette Tube, 12,5% Lycra	68
Cotton Stockinette	68
Dacron Tape	69
Casting Socks	69
Comfort Casting Socks	69
Transfer Paper	70
Thermoformable Composite (TFC), Sheets	71
Thermoformable Composite (TFC), Insole	72
Bars	73
TFC Upright Bars & Silicone Forming Sleeve	73
Cotton Stockinette	74
Teflon Sheet	74
Silicone Sheet	75
Vacuum Bag material	75



Fillauer Product Warranty

Fillauer items under warranty will be replaced or repaired (at Fillauer's discretion) at no charge, if the material or workmanship is found to be defective. Normal wear is not warranted. The warranty will be void if the item has been: a. fabricated or installed outside Fillauer's recommendations b. modified c. exposed to a corrosive environment d. if used outside of the products intended use. Below is a summary of warranties.

ORTHOTIC, PROSTHETIC COMPONENTS AND EQUIPMENT

are warranted for 12 months from the date of shipment from the Fillauer warehouse or from an authorized Fillauer distributor with the following exceptions:

SUSPENSION SLEEVES, SILICONE GLOVES, SPINAL BRACES & CUSTOM LINERS/SLEEVES

are warranted for 3 months from the date of shipment from the Fillauer warehouse or from an authorized Fillauer distributor.

Custom Fabrication Items, Prosthetic Liners, Dream Skin, Foot Shells, Cosmetic Gloves, Passive Hands and Trautman Tools & Accessories are warranted for 6 months from the date of shipment from the Fillauer warehouse or from an authorized Fillauer distributor.

HOSMER HOOKS

are warranted for 18 months from the date of shipment from the Fillauer warehouse or from an authorized Fillauer distributor.

ELBOWS

are warranted for 18 – 24 months from the date of shipment from the Fillauer warehouse or from an authorized Fillauer distributor. See specific product warranty for more information.

FILLAUER FEET

are warranted for 12, 24, or 36 months

12 months: Running Blade

24 months: AllPro, K2, Motion Foot® MX, Formula and Raize

36 months: Aeris Activity, Aeris Performance 2, Aeris Performance LP, Element, Element DS, Ibex XD, and Wave Comfort 3

COAPT & TASKA

Are warranted for 24 months from the date of shipment from the Fillauer warehouse or from an authorized Fillauer distributor.

All warranties are voided by alteration or misuse of the product.

Returns, Adjustments, and Credits

Inspect all goods immediately upon receipt for damage or errors in shipping. Call Customer Service within 3 business days in the event of errors or damage. Credit will not be issued for custom items made to specification or non-stock items older than 30 days, unless Fillauer shipped in error or there is defect in materials or workmanship.

Prior approval and a return authorization number must be obtained from Customer Service for all goods returned. Credit for returned merchandise is subject to inspection and may be subject to a 15% restocking fee for merchandise in resalable condition. Goods returned without prior approval may be subject to a 25% restocking fee. No credit shall be issued for goods that are more than 12 months old. Returns must be returned in unopened sellable packaging accompanied by a copy of original invoice, order number, or PO number. The return authorization number, provided by Customer Service, must appear on the shipping label.



Catalog symbol legend

Specification symbols

-
- SE** Manufactured in Sweden
-
- US** Manufactured in USA
-
- ES** Manufactured in Spain
-

Color symbols

-
-  CC03/Tan
-
-  CC99/Black
-
-  Grey
-
-  Green
-
-  Pink
-
-  Orange
-

Trautman Carvers & Sanders

Specification symbols

SE Manufactured in Sweden

US Manufactured in USA



Trautman Arbor 5001

US

Specifications

Height: 48 in. (122 cm)**Speed:** 1725 rpm**Width:** 47 in. (119 cm)**Thread:** 1/2"-13**Base plate:** 25 x 20 in. (635 x 508 mm)**Warranty:** 12 months from the date of shipment**Weight:** 560 lbs. (254 kg)

Product Features

The 5001 Trautman Arbor has powerful Baldor 2 HP, 60 HZ, 1 phase 115/230 V or 230/460 V motor. It comes with a 14 in. (350 mm) disc and an 8 in. (200 mm) Pneumatic Sanding Drum.

- Dual drive belts
- 2 horse power, Baldor motor
- 1725 rpm at 60Hz
- Durable powder coated finish

Ordering information

TRAUTMAN ARBOR

DESCRIPTION	PRODUCT NUMBER
Trautman Arbor, Single Phase, 50Hz, 230 V	5001-1-50
Trautman Arbor, Three Phase, 50Hz, 460 V	5001-3-50

SAND DISC

DESCRIPTION	PRODUCT NUMBER
Sand Disc, 24 Grit	A24

SAND CONES FOR NON-PNEUMATIC DRUMS

DESCRIPTION	PRODUCT NUMBER
Sand Drum Sleeve, 24 Grit	S24
Sand Drum Sleeve, 50 Grit	S50
Sand Drum Sleeve, 120 Grit	S120
Sand Drum Sleeve, 180 Grit	S180
Sand Drum Sleeve, 240 Grit	S240

SAND DRUM SLEEVES - PNEUMATIC

DESCRIPTION	PRODUCT NUMBER
Sand Drum Sleeve Fine-120 Grit	225247
Sand Drum Sleeve Fine-100 Grit	225248
Sand Drum Sleeve Coarse-36 Grit	225249

Trautman Double Drum Sander

US

Specifications

Height: 44 in. (112 cm)

Width: 45 in. (114 cm)

Weight: 535 lbs. (243 kg)

Speed: 1725 rpm

Warranty: 12 months from the date of shipment

Product Features

The Trautman 5005 DD Sander comes with same motor, motor control, dual drive belts with guard and base as 5001 Arbor. This machine has two 9 in. (23 cm) Pneumatic Sanding Drums.

- Dual drive belts
- 2 horse power, Baldor® motor
- Durable powder coated finish



Ordering information

TRAUTMAN DOUBLE DRUM SANDER

DESCRIPTION	PRODUCT NUMBER
Trautman Arbor, Single Phase, 50Hz, 230 V	5005-1-50
Trautman Arbor, Three Phase, 50Hz, 460 V	5005-3-50

SAND CONES FOR NON-PNEUMATIC DRUMS

DESCRIPTION	PRODUCT NUMBER
Sand Drum Sleeve, 24 Grit	S24
Sand Drum Sleeve, 50 Grit	S50
Sand Drum Sleeve, 120 Grit	S120
Sand Drum Sleeve, 180 Grit	S180
Sand Drum Sleeve, 240 Grit	S240

SAND DRUM SLEEVES - PNEUMATIC

DESCRIPTION	PRODUCT NUMBER
Sand Drum Sleeve Fine-36 Grit	225185
Sand Drum Sleeve Fine-120 Grit	225194



Trautman Variable Speed Floor Carver

US

Specifications

Height: 63 in. (160 cm)

Working Height: 26 - 56 in. (66 - 142 cm)

Weight: 228 lbs. (103 kg)

Speed: 1380 - 3450 rpm, 115 V (1380 - 2860 rpm, 230 V)

Thread: 1/2"-13 or 5/8"-11

Warranty: 12 Months from the date of shipment

Product Features

- Precise speed control for best results possible
- Heavy duty 3/4 hp Baldor® motor and controller
- Brushless motor for low maintenance
- Motor is thermally protected to prevent damage from overheating
- Factory lubricated and sealed bearings for long-lasting use
- Pre-attached 40 watt work light for the 60 Hz machine
- Fully adjustable height and tilt
- Torque overload safety feature
- Heavy duty base for stability



Floor Carver
shown with
Carver Lift Assist

Ordering information

TRAUTMAN VARIABLE SPEED FLOOR CARVER

DESCRIPTION	FREQUENCY	THREAD	PRODUCT NUMBER
Trautman Floor Carver	60 Hz, 115 V	1/2"-13	2300/60
Trautman Floor Carver	50 Hz, 230 V	1/2"-13	2300/50
Anchor Bolt System			390900
Lift assist holder			2100LA
Accessory Holder			2300M

Trautman Single Speed Floor Carver

US

Specifications

- Height:** 63 in. (160 cm)
- Working Height:** 26 - 56 in. (66 - 142 cm)
- Weight:** 219 lbs (99 kg)
- Speed:** 3450 rpm, 115 V (2860 rpm, 230 V)
- Thread:** 1/2"-13
- Warranty:** 12 Months from the date of shipment

Product Features

- Durable 1/2 hp Baldor® Motor
- Brushless motor for low maintenance
- Motor is thermally protected to prevent damage from overheating
- Factory lubricated and sealed bearings for long-lasting use
- Pre-attached 40 watt work light for the 60 Hz machine
- Fully adjustable height and tilt
- Torque overload safety feature
- 5/8"-11 threaded accessories may be used with Trautman Router Adapter, PN 225029



Floor Carver
shown with
Carver Lift Assist

Ordering information

TRAUTMAN SINGLE SPEED FLOOR CARVER

DESCRIPTION	PRODUCT NUMBER
Trautman Floor Carver, Single Speed, 50 Hz, 230 V	2100/50
Anchor Bolt System	390900
Lift Assist Holder	2100LA
Accessory Holder	2300M



Trautman Tech Station

US

Specifications

Height: 70 in. (180 cm)

Width: 37 in. (94 cm)

Depth: 36 in. (91 cm)

*Shipping Weight: 190 lbs (86 kg)

Warranty: 12 Months from the date of shipment

Product Features

- State-of-the-art modular, multipurpose workstation
- Small footprint maximizes workspace
- 360-degree rotation with easy adjustments
- Base unit can be modified with various attachments and accessories for custom needs

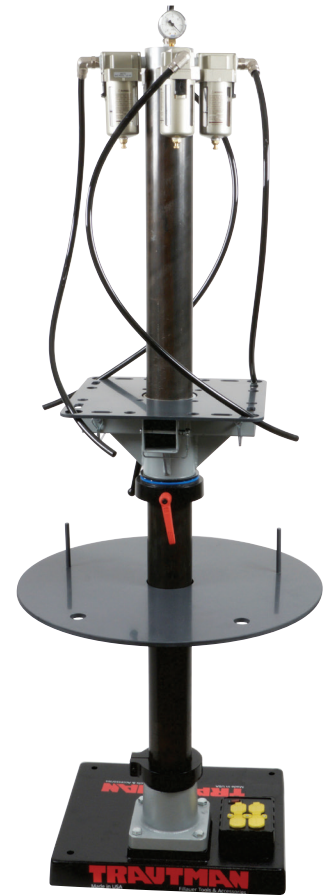

Ordering information

TRAUTMAN TECH STATION

DESCRIPTION	SHIPPING WEIGHT	PRODUCT NUMBER
Trautman Tech Station	86 kg	395400

TRAUTMAN TECH STATION ATTACHMENTS

DESCRIPTION	SHIPPING WEIGHT	PRODUCT NUMBER
Trautman Tech Pipe Vise	4kg	395012
Trautman Tech Pipe Vise with Drop Hitch	6 kg	395250
Trautman Tech Drape Forming Pipe Holder	5 kg	395550
Trautman Tech Attachment for Bench Carver	3 kg	395050
Trautman 12 in. Platen	5 kg	227347
Trautman Tech LJ-100 Adapter	5 kg	395810

Dust Collector for Floor Carver

US

Product Features

- Infinitely adjustable
- Steel construction
- 4 in. (10 cm) exhaust for connection to vacuum system



Ordering information

DESCRIPTION	PRODUCT NUMBER
Dust Collector for Floor Carver	2100L

Dust Collection Hose Kit for 2100L

US

Product Features

- For use with Dust Collector for Floor Carver (PN 2100L)
- 4 in. (10 cm) diameter clear hose for viewing any obstruction
- 6 ft. (1.8 m) of flexible hose reach
- 2 worm-drive clamps for connection
- Internal abrasion resistant
- Enclosed steel wire reinforced



Ordering information

DESCRIPTION	PRODUCT NUMBER
Dust Collection Hose Kit for 2100L	226005



Air Attachment for Floor Carver

US

Product Features

The air attachment directs an adjustable air stream to blow dust and chips from the cutting tool and to assist in cooling down thermoplastic grinding for more efficient grinding. Standard 1/4 in. (0.6 cm) pipe fitting to be attached to your air supply.

- Features a flat air flow nozzle
- Flexible stay set hose for adjustable air stream



Ordering information

DESCRIPTION

Air Attachment for Floor Carver

PRODUCT NUMBER**2100J**

Accessory Holder for Floor Carver

US

Product Features

- Round, rotatable carousel design
- Keeps accessories organized, visible and accessible
- 23 total peg locations, includes 8 long and 23 short pegs for custom peg layouts

NOTE: Accessories not included



Accessories sold separately

Ordering information

DESCRIPTION

Accessory Holder for Floor Carver

PRODUCT NUMBER**2300M**

Lift Assist Kit for Floor Carver

US

Product Features

- Assists in both lifting and lowering
- Easy to install
- Provides over 16 in. (40 cm) of adjustment
- Works on all Trautman models, past and current
- Thrust bearing for ease of rotation
- Shock provides slam-resistant damping at the end of the stroke



Ordering information

DESCRIPTION	PRODUCT NUMBER
Carver Lift Assist	2100LA



Trautman Variable Speed Bench Carver

US

Specifications

Height: 22 in. (56 cm) **Speed:** 1380 - 3400 rpm, 115 V (1380 - 2820 rpm, 230 V)
Working Height: 15 - 22 in. (38 - 56 cm) **Thread:** 1/2"-13
Weight: 28 lbs. (12.7 kg) **Warranty:** 12 months from the date of shipment

Product Features

- Maintenance-free 1/3 hp motor and controller
- High quality variable speed motor controller
- Lubricated ball bearings, sealed for life



Ordering information

TRAUTMAN ARBOR

DESCRIPTION	PRODUCT NUMBER
Trautman Bench Carver, Variable Speed, 50 Hz, 230 V, 1/2"-13 Thread	2600/50

Trautman Single Speed Bench Carver

US

Specifications

Height: 22 in. (56 cm) **Speed:** 3400 rpm, 115 V (2820 rpm, 230 V)
Working Height: 15 - 22 in. (38 - 56 cm) **Thread:** 1/2"-13
Weight: 25 lbs. (11.3 kg) **Warranty:** 12 Months from the date of shipment

Product Features

- Great for satellite offices or bench work
- Maintenance free 1/3 hp motor
- Lubricated sealed ball bearings
- 5/8-11 threaded accessories may be used with Trautman Router Adapter, PN 225029)



Ordering information

TRAUTMAN ARBOR

DESCRIPTION	PRODUCT NUMBER
Trautman Bench Carver, 50 Hz, 230 V, 1/2"-13 Thread	2500/50

Bench Carver Floor Stand

US

Product Features

- Adjustable height 35 – 56 in. (89 - 142 cm)
- Alloy screw adjusts clamping force



Ordering information

DESCRIPTION

Bench Carver Floor Stand

PRODUCT NUMBER

390190

Accessory Holder for Bench Carver

US

Product Features

- Keeps accessories organized, visible, and accessible



Ordering information

DESCRIPTION

Accessory Holder for Bench Carver

PRODUCT NUMBER

2500M

Dust Collector for Bench Carver

US

Product Features

- Works with most workshop vacuum systems
- Flexible gooseneck for wide range of adjustment
- Appropriate for bench carvers and for hand-held sanding tools



Ordering information

DESCRIPTION

Dust Collector for Bench Carver

PRODUCT NUMBER

2500L



Drill Attachments 1/2"-13 Thread

US



Ordering information

PRODUCT FEATURES	PRODUCT NUMBER
Trautman Drill Attachment - Fits up to 3/8 in. shaft	2100S

Cutters & Replacement Blades

US



2100B

2100H

Ordering information

CUTTERS

DESCRIPTION	PRODUCT NUMBER
Cutter, 1/2"-13 Thread, small	2100H

REPLACEMENT BLADES

DESCRIPTION	PRODUCT NUMBER
Replacement Blades, small	2100HB

Soft Foam Shaper

US

Specifications

Length: 5 in. (12 cm)

Thread: 5/8"-11

Max. Diameter Schmid Carver: 2-3/4 in.



Product Features

- Ideal for contouring both inner and outer areas of foam cover
- Fine steel bristles barely protrude through surface so foam material may be shaped quickly and removed to obtain the desired cosmetic finish
- Trautman Router Adapter required (PN 225029)

Ordering information

DESCRIPTION	PRODUCT NUMBER
Soft Foam Shaper	51391

Shaft Foam Arbors

US

Ordering information

FOAM ARBOR FOR FLOOR CARVER

DESCRIPTION	PRODUCT NUMBER
Shaft Foam Arbor for Floor Carver, 3 × 9 in.	2100X

FOAM ARBOR FOR BENCH CARVER

DESCRIPTION	PRODUCT NUMBER
Shaft Foam Arbor for Bench Carver, 3 × 5-1/2 in.	2500X

2100X SAND CONES

DESCRIPTION	PRODUCT NUMBER
Sand Cone for 2100X, 36 Grit	225240
Sand Cone for 2100X, 60 Grit	225242
Sand Cone for 2100X, 120 Grit	225244

2500X SAND CONES

DESCRIPTION	PRODUCT NUMBER
Sand Cone for 2500X, 36 Grit	225230
Sand Cone for 2500X, 60 Grit	225232
Sand Cone for 2500X, 120 Grit	225234





Urethane and Felt Arbors

US

Product Features

- **Urethane Arbors:** Most commonly used for shaping soft foam covers
- **Felt Arbors:** Used for polishing plastic edges
- Can be shaped to any contour



225080

Ordering information

URETHANE FEATURES

DESCRIPTION	PRODUCT NUMBER
Urethane Arbor, 3 × 5 in., 5/8"-11 Thread	225080
Urethane Arbor, 3 × 5 in., 1/2"-13 Thread	225082
Urethane Arbor, 1.5 × 4.5 in., 5/8"-11 Thread	225520

Pneumatic Sand Drum

US

Ordering information



PNEUMATIC SAND DRUM 3.5 X 5 IN.

DESCRIPTION	PRODUCT NUMBER
Pneumatic Sand Drum, 1/2"-13 Thread	224100

SAND DRUM SLEEVES - PNEUMATIC

DESCRIPTION	PRODUCT NUMBER
Sand Sleeve, 120 Grit	224101
Sand Sleeve, 80 Grit	224102
Sand Sleeve, 36 Grit	224103

Sand Drum

US

Ordering information

SAND SHEETS - SMALL

DESCRIPTION	PRODUCT NUMBER
Sand Sheet, 60 Grit	F60

Rubber Sand Cones

US

Specifications

Length: 4-3/8 in. (111 mm)

Thread: 1/2"-13

Ordering information

Mini Sand Core



MINI SAND CORE

DESCRIPTION	PRODUCT NUMBER
Sand Core, Mini	2100P

MINI SANDING SLEEVES

DESCRIPTION	PRODUCT NUMBER
Mini 50 Grit	P50
Mini 100 Grit	P100
Mini 180 Grit	P180

MINI POLISHING CONE

DESCRIPTION	PRODUCT NUMBER
Mini, Fine, Blue	225117
Mini, Medium, Maroon	225118
Mini, Coarse, Brown	225119

Small Sand Core



SMALL SAND CORE

DESCRIPTION	PRODUCT NUMBER
Sand Core, Small	2100D

SMALL SANDING SLEEVES

DESCRIPTION	PRODUCT NUMBER
Small 24 Grit	D24
Small 80 Grit	D80
Small 120 Grit	D120

SMALL POLISHING CONE

DESCRIPTION	PRODUCT NUMBER
Small, Fine, Blue	225111
Small, Medium, Maroon	225112

Medium Sand Core



MEDIUM SAND CORE

DESCRIPTION	PRODUCT NUMBER
Sand Core, Medium	2100C

MEDIUM SANDING SLEEVES

DESCRIPTION	PRODUCT NUMBER
Medium 24 Grit	C24
Medium 80 Grit	C80
Medium 120 Grit	C120
Medium 180 Grit	C180
Medium 240 Grit	C240
Medium 320 Grit	C320

MEDIUM POLISHING CONE

DESCRIPTION	PRODUCT NUMBER
Medium, Fine, Blue	225114
Medium, Medium, Maroon	225115
Medium, Coarse, Brown	225116



Tapered Felt Arbor/ Core

US



Ordering information

1×4 IN. FELT ARBORS & SAND CONES

DESCRIPTION	PRODUCT NUMBER
1 × 4 in. Sand Cone, 80 Grit	225173
1 × 4 in. Sand Cone, 120 Grit	225175

1.5×4 IN. FELT ARBORS & SAND CONES

DESCRIPTION	PRODUCT NUMBER
1.5 × 4 in. Sand Cone, 36 Grit	225151
1.5 × 4 in. Sand Cone, 100 Grit	225169
1.5 × 4 in. Sand Cone, 120 Grit	225171

2×4 IN. FELT ARBORS & SAND CONES

DESCRIPTION	PRODUCT NUMBER
2 × 4 in. Sand Cone, 36 Grit	225136
2 × 4 in. Sand Cone, 80 Grit	225141

Expansion Arbors

US

Specifications

Warranty: 6 months against manufacturing defects

Product Features

- Expands to apply inside pressure to the sanding sleeve to hold it in place
- Prevents migration and “Fly away” of sanding sleeve
- Provides a smoother grinding surface for straighter lines and higher quality finish
- Eliminates grinding chatter that hard grinding surfaces gives
- Sold individually and as a kit of three
- Available in 1/2”-13, 5/8”-11 and M16 threads to fit most O&P machinery



Ordering information

EXPANSION ARBOR KITS

DESCRIPTION	PRODUCT NUMBER
1/2-13 Threads	225380
M16 Threads	225380MM

Mini



MINI EXPANSION ARBOR

DESCRIPTION	PRODUCT NUMBER
1/2”-13 Thread	225350
M16 Thread	225350MM

MINI SANDING SLEEVES

DESCRIPTION	PRODUCT NUMBER
Mini 50 Grit	P50
Mini 100 Grit	P100
Mini 180 Grit	P180

Small



SMALL EXPANSION ARBOR

DESCRIPTION	PRODUCT NUMBER
1/2”-13 Thread	225352
M16 Thread	225352MM

SMALL SANDING SLEEVES

DESCRIPTION	PRODUCT NUMBER
Small 24 Grit	D24
Small 80 Grit	D80
Small 120 Grit	D120

Medium



MEDIUM EXPANSION ARBOR

DESCRIPTION	PRODUCT NUMBER
1/2”-13 Thread	225354
M16 Thread	225354MM

MEDIUM SANDING SLEEVES

DESCRIPTION	PRODUCT NUMBER
Medium 24 Grit	C24
Medium 80 Grit	C80
Medium 120 Grit	C120
Medium 180 Grit	C180 (metal use)
Medium 240 Grit	C240 (metal use)
Medium 320 Grit	C320 (metal use)



Dual Purpose Expansion Arbors

US

Specifications

Warranty: 6 months against manufacturing defects

Product Features

- Sand and polish without changing tools
- Removable, tapered polishers for easy replacement

Ordering information

Small



SMALL DUAL PURPOSE

DESCRIPTION	PRODUCT NUMBER
1/2"-13 Threads	225330
5/8"-11 Threads	225335
M16 Threads	225330MM
Slim Blue Coneiak, Replacement tip	225345

SMALL SANDING SLEEVES

DESCRIPTION	PRODUCT NUMBER
Small 24 Grit	D24
Small 80 Grit	D80
Small 120 Grit	D120

Medium



MEDIUM DUAL PURPOSE

DESCRIPTION	PRODUCT NUMBER
1/2"-13 Threads	225320
5/8"-11 Threads	225325
M16 Threads	225320MM
Tapered Red Coneiak, Replacement tip	225340

MEDIUM SANDING SLEEVES

DESCRIPTION	PRODUCT NUMBER
Medium 24 Grit	C24
Medium 80 Grit	C80
Medium 120 Grit	C120
Medium 180 Grit	C180 (metal use)
Medium 240 Grit	C240 (metal use)
Medium 320 Grit	C320 (metal use)

Grinding Rasps

US

Product Features

Warranty: 6 months against manufacturing defects

- High-quality steel
- Sharp teeth
- Long usage

Ordering information

5/8"-11 THREAD*

DESCRIPTION	PRODUCT NUMBER
1-1/2 × 2-1/4 in. - Use on Transtibial Sockets, Coarse	225052
1-3/8 × 3-3/8 in. - Small Diameter and Channel Work, Coarse	225045
1-3/8 × 2-1/8 in. - Extra Fine	225060
1-3/4 × 3-1/8 in. - General Transfemoral Socket Work, Coarse	225037

*Must have router adapter for 5/8-11 threaded Rasps

1/2"-13 THREAD

DESCRIPTION	PRODUCT NUMBER
Rasp	2100E
Carbide Grind Rasp, Large, Fine	225256
Carbide Grind Rasp, Small, Coarse	225262
Carbide Grind Rasp, Small, Fine	225266
Used most commonly for grinding laminated sockets	

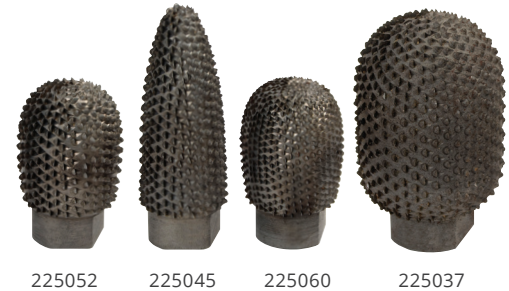

225052 225045 225060 225037



2100E 225256 225262 225266

Router Adapters

US

Specifications

Warranty: 6 months against manufacturing defects

Ordering information

1/2"-13 INTERNAL THREAD

DESCRIPTION	PRODUCT NUMBER
5/8-11 External Thread	225029
M16 External Thread	225017

1/2"-13 EXTERNAL THREAD

DESCRIPTION	PRODUCT NUMBER
5/8-11 Internal Thread	225011
M16 Internal Thread	225016



225017 225029



225011 225016



Tycro Polishing Arbor

US

Specifications

Warranty: 6 months against manufacturing defects



Ordering information

TYCRO POLISHING ARBOR

DESCRIPTION	PRODUCT NUMBER
Tycro Polishing Arbor, 3 x 3-1/2 in., Double Ended with 5/8 in. and 1/2 in. Thread	225110

TYCRO ACCESSORIES

DESCRIPTION	PRODUCT NUMBER
Tycro Cone, 4 x 1 in. (Requires 225090)	225100
Tycro Cone Adapter, 1/2 in. Thread	225090

Trautman Coneiak Polishing Arbors

US

Specifications

Warranty: 6 months against manufacturing defects

Product Features

- All Coneiak Polishing Arbors work well with any standard thermoplastic materials within the O&P industry.
- For best results, drill attachment 2100S (large) or 2100R (small) should be used
- If using a rotary hand tool, the maximum speed should not exceed 10,000 RPMs
- Ensure that the shaft is at least halfway into chuck



Ordering information - Coneiak Mini Polishing Arbor

DESCRIPTION	SHAFT	PRODUCT NUMBER
Set of Five Coneiak Minis	1/8 in.	225650
Tapered Coneiak Mini	1/8 in.	225600
Ball Nose Coneiak Mini	1/8 in.	225615
Slim Coneiak Mini	1/8 in.	225605
Cylindrical Coneiak Mini	1/8 in.	225620
Double Ended Coneiak Mini	1/8 in.	225610



Ordering information - Trautman Coneiak Polishing Arbor

US

SET OF FOUR CONEIAKS

DESCRIPTION	PRODUCT NUMBER
1/2"-13 Thread	225490
5/8"-11 Thread	225495
M16 Thread	225490MM



TAPERED CONEIAK

DESCRIPTION	PRODUCT NUMBER
1/2"-13 Thread	225410
5/8"-11 Thread	225415
M16 Thread	225410MM



BALL NOSE CONEIAK

DESCRIPTION	PRODUCT NUMBER
1/2"-13 Thread	225400
5/8"-11 Thread	225405
M16 Thread	225400MM



SLIM CONEIAK

DESCRIPTION	PRODUCT NUMBER
1/2"-13 Thread	225440
5/8"-11 Thread	225445
M16 Thread	225440MM



CYLINDRICAL CONEIAK

DESCRIPTION	PRODUCT NUMBER
1/2"-13 Thread	225450
5/8"-11 Thread	225455
M16 Thread	225450MM



HOURGLASS CONEIAK

DESCRIPTION	PRODUCT NUMBER
1/2"-13 Thread	225430
5/8"-11 Thread	225435
M16 Thread	225430MM



GROOVED CONEIAK

DESCRIPTION	PRODUCT NUMBER
1/2"-13 Thread	225420
5/8"-11 Thread	225425
M16 Thread	225420MM



DOUBLE DUROMETER

DESCRIPTION	PRODUCT NUMBER
1/2"-13 Thread	225460
5/8"-11 Thread	225465
M16 Thread	225460MM



Trautman Vacuum Systems

Specification symbols

SE Manufactured in Sweden

US Manufactured in USA



Mobile Vacuum Unit

US

Specifications

Warranty: 12 months from the date of shipment



Product Features

- Multifunction table top for pipe-mounted platens, vacuum forming, or pipe-holding fixture for horizontal vacuum forming
- Master cut-off valve and three-way valve
 - Neutral (Off) position
 - High vac line—full vacuum direct from vacuum source
 - Low vac line—controlled by regulator
- Veritable On/Off foot pedal
- Filter and water trap (wet plaster models release 4–6 oz. of water which could contaminate regulator, gauges, and pump)
- Two 3 gallon surge tanks for rapid vacuum

Ordering information

Note: Pump is sold separately.

DESCRIPTION	PRODUCT NUMBER
Mobile Vacuum Unit	227305
SPARE PARTS	
227503 - Surge Tanks	
227511 - Master Cut-Off Valve	
227529 - Three-Way Valve	
227537 - Regulator	
227545 - Gauge	
227552 - Filter-Water Trap	
227560 - On/Off Foot Control	

Vacuum Control Assembly

US

Ordering information

DESCRIPTION	PRODUCT NUMBER
Vacuum Control Assembly	227500
SPARE PARTS	
227511 - Master Cut-Off Valve	227545 - Gauge
227529 - Three-Way Valve	227552 - Filter-Water Trap
227537 - Regulator	



Portable Oilless Vacuum Pump

US

Product Features

- 1/3 Horse Power oilless motor
- Enough power to operate two vacuum laminating jigs simultaneously
- 4 cubic feet per minute capacity
- Adjustable vacuum from 3 - 27 in. of mercury (10 - 90 kPa)
- Available in single and dual vacuum
- US plug 115 V, 50/60 Hz Single Phase Motor or EU 230 v, 50 Hz
- Reversible to become air supply as well as vacuum
- 12 month warranty from date of shipment



Ordering information

DESCRIPTION	PRODUCT NUMBER
Portable Single Oilless Vacuum Pump, 115 V	227005
Portable Dual Oilless Vacuum Pump, 115 V	227020
Portable Single Oilless Vacuum Pump, 230 V	227006
Portable Dual Oilless Vacuum Pump, 230 V	227021



Holding Frames

US

Product Features

- Black powder coated for durability

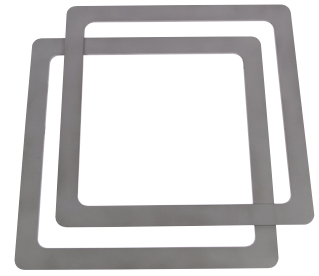

Ordering information

Note: Sold per pair

DESCRIPTION	PRODUCT NUMBER
Holding Frames, 12 × 12 in.	227420
Holding Frames, 16 × 16 in.	227438
Holding Frames, 18 × 18 in.	227443
Holding Frames, 20 × 20 in.	227449
Holding Frames, 22 × 22 in.	227450
Holding Frames, 24 × 24 in.	227451

Drape Forming Adapters

US



Ordering information

DRAPE FORMING ADAPTER

DESCRIPTION	PRODUCT NUMBER
Drape Forming Adapter, Straight	227497
Drape Forming Adapter, Angled	227495

PLATEN

DESCRIPTION	PRODUCT NUMBER
9 in. Platen	227354
12 in. Platen	227347

Trautman Vacuum Stations

US

Specifications

Warranty: 12 months from the date of shipment

Product Features

The Trautman Dual Bladder Vacuum Station allows for a variety of options in vacuum forming. The station can be used as either a dual bladder or single bladder vacuum system. The dual bladder configuration allows for better mold preservation during vacuum forming and improved surface quality of the molded product. This allows the product to be more consistent and visually appealing.

Single bladder vacuum stations can be easily upgraded to a dual bladder configuration by purchasing the upgrade kit (see optional accessories below).

- Durable, powder coated, aluminum frame
- High temperature, non-stick, clear silicone bladder
- Dual bladder for use with Comfil® TFC and pre-preg materials
- Quick change outer bladder saves time and money
- Exterior dimension: 24 × 24 in. (61 × 61 cm)
- Work area 18.5 × 18.5 in. (47 × 47 cm)
- Requires vacuum source



Ordering information

TRAUTMAN VACUUM STATIONS

DESCRIPTION	PRODUCT NUMBER
Dual Bladder Vacuum Station	227730
Single Bladder Vacuum Station	227728

ACCESSORIES

DESCRIPTION	PRODUCT NUMBER
Dual Bladder Upgrade	227729
Outer Bladder	227752
Inner Bladder	227751



PDQ Ovens

Specification symbols

SE Manufactured in Sweden

US Manufactured in USA

PDQ Rollabout Oven

US

Specifications

Electrical requirements: US 208 - 240 V single phase
EU 380 - 460 V three phase

Warranty: 12 months from the date of shipment

Product Features

A Rollabout model is an excellent solution for heating large sheets of plastic for hip. There are 4 different sizes to meet every thermoforming need, and each features a hydraulic assisted height adjustable tray for easy operation. The tray includes a fitted Teflon® cover, is mounted on casters, and can be rolled to your vacuum area. No more burnt arms or trying to find a place to set down your hot plastic.

- Aluminum and stainless steel construction
- 650 watt infrared emitters (1000 watt on 8E & 8D)
- Double pane viewing window & interior light
- Programmable digital temperature controller
- Tray includes a fitted Teflon® cover
- NOTE: 208 - 240 V, single phase ovens delivered without cord
380 - 460 V, three phase ovens delivered with cord, no plug



Shown with the PDQ Oven Fan Kit.
See page 37 for more information.

Dimensions

MODEL	INTERIOR DIMENSIONS (W X D X H)	EXTERIOR DIMENSIONS (W X D X H)	WEIGHT
PDQ-5A	38 × 31 × 18 in. (965 x 787 x 457 mm)	49 × 35 × 48 in. (1244 x 889 x 1219 mm)	350 lbs. (159 kg)
PDQ-6B	36 × 51 × 18 in. (914 x 1295 x 457 mm)	47 × 55 × 48 in. (1194 x 1397 x 1219 mm)	450 lbs. (204 kg)
PDQ-7C	48 × 51 × 18 in. (1219 x 1295 x 457 mm)	59 × 55 × 48 in. (1499 x 1397 x 1219 mm)	460 lbs. (209 kg)
PDQ-8E	60 × 50 × 18 in. (1524 x 1219 x 457 mm)	70 × 52 × 48 in. (1778 x 1321 x 1219 mm)	475 lbs. (215 kg)

Ordering information

MODEL	PROD NO. EU 400 V, 50 HZ, THREE PHASE
PDQ-5A	O5A-INT
PDQ-6B	O6B-INT
PDQ-7C	O7C-INT
PDQ-8E	O8E-INT



PDQ BT-4 Infrared Oven

US

Specifications

Electrical requirements: US 208 - 240 V single phase
EU 380 - 460 V three phase

Warranty: 12 months from the date of shipment

Product Features

The BT-4 is capable of bubble forming and heating sheet plastic while taking up a minimal amount of floor space. The BT-4 Infrared Oven is big enough to heat most KAFO sheet plastics and has enough drop for even the biggest check socket.

The BT-4 has the same speed and reliability you've come to expect from PDQ Infrared Ovens. The eight 1000 watt emitters, four on top and four on bottom, along with the dual electric fans allow bubble forming plastics to be heated evenly and efficiently. The BT-4 is truly the best of both worlds with its small size and large capacity.

- Eight 1000 watt emitters; four on top and four on bottom
- Programmable digital temperature controller
- Dual electric fans for air circulation
- Access point for vacuum line
- 4 interior lights and large viewing window
- Sheet plastic tray with fitted Teflon® cover
- Aluminum and powder coated protective finish
- 18 in. (46 cm) clearance for bubble forming
- NOTE: US 220 V, single phase ovens delivered without cord
EU 440 V, three phase ovens delivered with cord, no plug



Ordering information

MODEL	INTERIOR DIMENSIONS (W x D x H)	EXTERIOR DIMENSIONS	PRODUCT NUMBER
PDQ-BT-4	27 × 40 × 24 in. (686 x 1016 x 610 mm)	32 × 49 × 61 in. (813 x 1245 x 1549 mm)	o-BT4-INT

PDQ PO-2 Infrared Oven

US

Specifications

Electrical requirements: US 208 - 240 V single phase
EU 380 - 460 V three phase

Warranty: 12 months from the date of shipment

Product Features

Designed with banks of lights on top and bottom to facilitate the quick and even forming of thick plastics.

Instead of having to reach into a hot oven for bubble forming frames, the PO-2 model now has a rollabout tray that holds either frames or trays for heating flat plastic. Just roll the cart out to your mold.

- Aluminum and stainless steel construction
- Quartz infrared tubes top and bottom
- Eight 1000 watt quartz infrared tubes (four on top and four on bottom)
- Interior light
- Two double pane viewing windows
- Programmable digital temperature controller (accurate to within 2°)
- Rollabout bubble forming rack/sheet plastic tray with fitted Teflon® cover
- Bubble Forming Frame (specify size at time of ordering)
- Full 1 year warranty
- NOTE: US 220 V, single phase ovens delivered without cord
EU 440 V, three phase ovens delivered with cord, no plug

Ordering information

MODEL	INTERIOR DIMENSIONS (W x D x H)	EXTERIOR DIMENSIONS	PRODUCT NUMBER
PDQ-PO-2	50 x 36 x 20 in. (1270 x 914 x 508 mm)	60 x 40 x 53 in. (1524 x 1016 x 1346 mm)	OPO2





PDQ Oven Fan Kit

US

Product Features

- Available as a retrofit kit for an existing PDQ Infrared Oven
- Available as factory-installed accessory on a new PDQ Infrared Oven
- Provides controlled heating of Pre-Preg and TFC materials
- Reduces production time by as much as 20 percent for O&P plastics
- Fits all models except BT-1 and BT-4

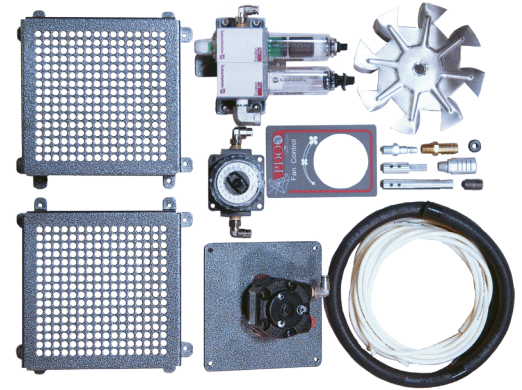

Ordering information

DESCRIPTION	PRODUCT NUMBER
Oven Fan Kit, for Retrofit	OFANKIT
Oven Fan Kit, for Factory Installed Accessory with oven order	OFANNEW

Tongue Tray

US

Product Features

1/2 in. H x 24 in. W x 24 in. D



Ordering information

DESCRIPTION	PRODUCT NUMBER
Tongue Tray	TRAYTONGUE

PDQ Oven Gloves

US

Product Features

- Provides protection against heat up to 250°F (120°C)
- 100% cotton
- 11 in. (28 cm) long for up to the elbow coverage



Ordering information

DESCRIPTION	PRODUCT NUMBER
PDQ Long Thermal Gloves	ORSUPGLOVE

Fabrication Equipment

Specification symbols

SE Manufactured in Sweden

US Manufactured in USA



Laminating Fixture LJ-100

US

Product Features

- Height: 24 in. (61 cm)
- Width: 17 in. (43 cm)
- May be positioned to hold cast at any angle or degree of rotation
- Large PVA tie-off ring and hose attachments for inside and outside vacuum lines make laminating easier and faster

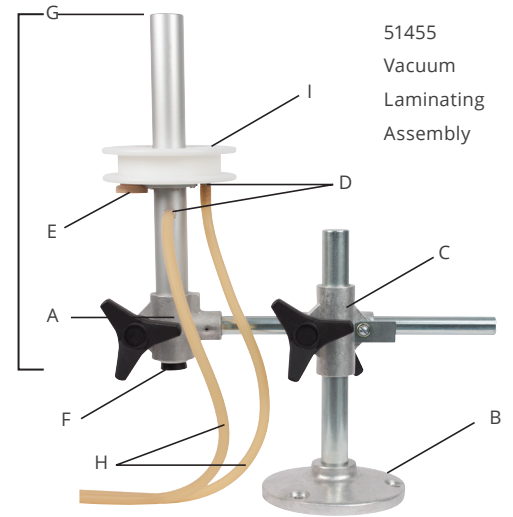

51459 Vacuum Laminating Device

Ordering information

DESCRIPTION	PRODUCT NUMBER
Laminating Fixture Complete, LJ-100	51454
Vacuum Device Assembly Only	51459
Vacuum Laminating Assembly Only	51455

SPARE PARTS FOR LJ100

- A. 51462 - Clamp Assembly
- B. 51463 - Post Base Assembly
- C. 52062 - Clamp Assembly
- D. 51271 - Hose Connector
- E. 51458 - Stopper
- F. 51457 - Plug
- G. 51456 - Pipe Lock
- H. Surgical Tubing (See Below)
- I. 55706 - Lamination Mandrell
- 51275 - Hose, Tie-Off 3/16 in., (Not Shown)

Surgical Tubing

US

Product Features

- High quality, pure latex tubing
- May be used as hose on vacuum or to securely tie-off PVA bags on the Vacuum Laminating Fixture, LJ-100

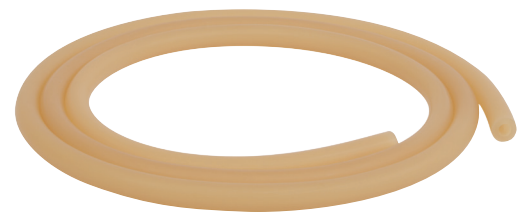

Ordering information

DESCRIPTION	PRODUCT NUMBER
Surgical Tubing, 0.25 in. (6.4 mm) Diameter, 6 ft. (183 cm) Increments Only	51273
Surgical Tubing, 0.19 in. (4.8 mm) Diameter, per foot	51275

Vertical Fabricating Fixture, VFJ-100

US

Product Features

- **Height:** 48-3/4 in. (124 cm)
- **Width:** 21 in. (53 cm)
- Horizontal operation
- Heavy-duty for long life
- Retractable handle when not in use
- Will form full circle without restriction



Ordering information

DESCRIPTION	PRODUCT NUMBER
Vertical Fabricating Fixture, VFJ-100	52056
Vertical Swivel Module	61714
VFJ-Ball Joint Module	58188
Flex Foot/Spring Lite LOHO Bock Adapter	58640
Endoskeletal Adapter, (Requires PN 58640)	58633



Bar Contouring Device

US

Product Features

- **Height:** 36 in. (914 mm)
- **Base area:** 24 x 38 in. (610 x 965 mm)
- Heavy-duty for long life
- Retractable handle when not in use
- Operates in two directions, in and out
- Available as floor model (with stand)
- Will form full circle without restriction

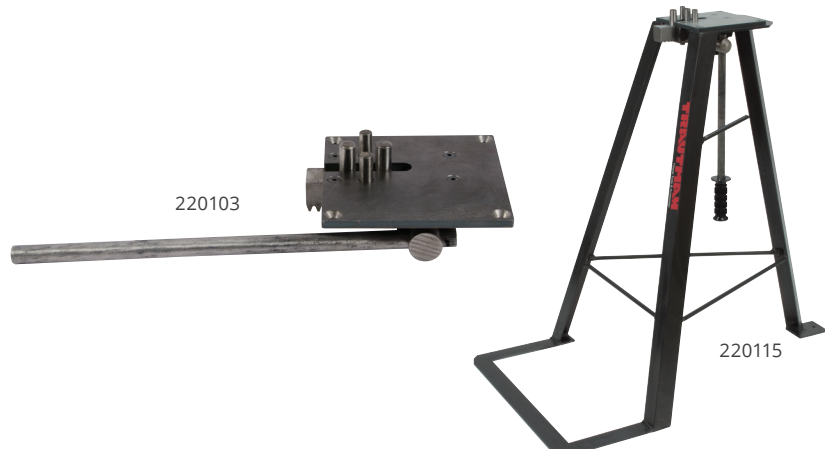

Ordering information

DESCRIPTION	PRODUCT NUMBER
Bar Contouring Device	220103
Bar Contouring Device, with Stand	220111
Stand Only	220115

Pipe Holding Fixtures

US

Ordering information

DESCRIPTION	PRODUCT NUMBER
Pipe Holding Fixture, Vice Mount	220129
Bench Mounted Pipe Holding Fixture, 8 in. Hi	220131
Friction Block	220135
Laminating Stand with Pipe Holding Fixture Adjustable in Height to 60 in. (152 cm), 15 - 18 in. (381 - 457 mm) Diameter	220133



220129

220131

220135

220133

Prosthetic Bench Vise

US

Product Features

- Tough, resilient pads
- Opens to 16 in. (406 mm) with an 8 in. (203 mm) depth
- Swivel jaw, 6 × 6 in. (152 x 152 mm)



Ordering information

DESCRIPTION	PRODUCT NUMBER
Prosthetic Bench Vise	220178
Replacement Pads	220301

Cable Swaging Tool

US

Product Features

- May be used in any standard bench vise
- Made of heat treated steel



Ordering information

DESCRIPTION	PRODUCT NUMBER
Cable Swaging Tool, for Three Sizes of Cable Size Fittings	50520

REPLACEMENT DIE

DESCRIPTION	PRODUCT NUMBER
Replacement Die, 3/64 in. (0.119cm)	US 524
Replacement Die, 1/16 in. (0.159cm)	50523
Replacement Die, 3/32 in. (0.238cm)	50522



Drill Press Fixture

US

Product Features

- For intricate orthotic and prosthetic work
- Less bulky than a table



Ordering information

DESCRIPTION	PRODUCT NUMBER
Drill Press Fixture, 2 - 2.25 in. (51 - 57 mm) Diameter	220160
Drill Press Fixture, 2.5 - 2.75 in. (64 - 70 mm) Diameter	220162
Drill Press Fixture, 3 - 3.25 in. (76 - 83 mm) Diameter	220164

Universal Alignment Fixture

US

Ordering information



DESCRIPTION	PRODUCT NUMBER
Universal Alignment Fixture	220128

Stirrup Bender

Product Features

- Length: 25 in. (381 mm)
- Width capacity: 3-5/8 in. (92.1 mm)

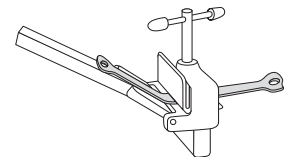

Ordering information

DESCRIPTION	PRODUCT NUMBER
Stirrup Bender	220038

Contouring Fork and Bench Receptacle

US

Product Features

- Heat-treated stainless steel
- Mounts flush on work bench or in work bench vise

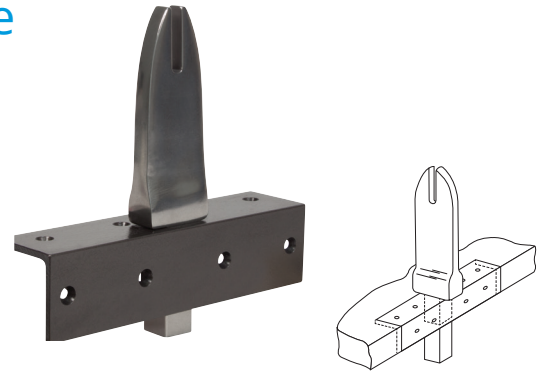

Ordering information

DESCRIPTION	PRODUCT NUMBER
Contouring Fork, 5/16 in. Throat	220194
Contouring Fork, 1/4 in. Throat	220186
Bench Receptacle	220202
Fork and Receptacle Set, 1/4 in. Throat	220210
Fork and Receptacle Set, 5/16 in. Throat	220293

Joint Alignment Tool

US

Product Features

- Use for both small and large stirrups

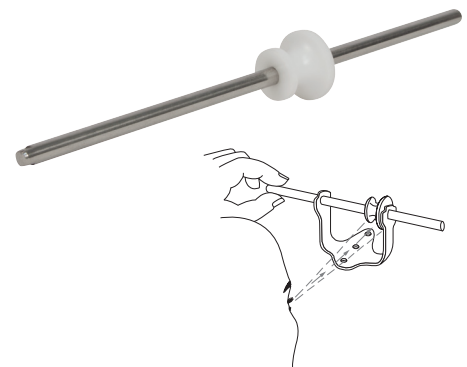

Ordering information

DESCRIPTION	PRODUCT NUMBER
Alignment Tool, Universal 0.25 in. diameter × 8 in. long rod	220194



Bending Irons

US

Product Features

- 8 in. (203 mm) long, 1/4 in. (6.4 mm) thickness capacity
- Stainless steel
- Provides smooth bending of side bars
- Sold as a pair

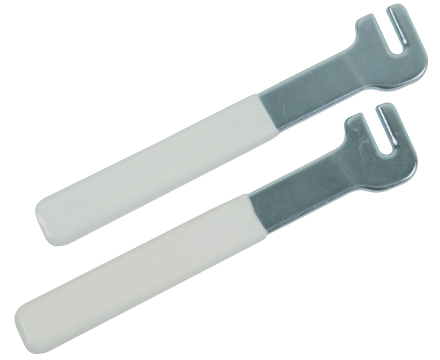

Ordering information

DESCRIPTION	PRODUCT NUMBER
Bending Irons	54795

Contouring Irons

US

Product Features

- Nickel plated bronze
- Wide-radius jaws
- Sold as a pair
- Will not mark finished metal or leather work



Ordering information

DESCRIPTION	PRODUCT NUMBER
Rounded Polished Jaws	220285

Spring Clamps

US



Ordering information

DESCRIPTION	PRODUCT NUMBER
Spring Clamps Set (4 Each)	227594

Yates Clamp

US

Product Features

- Holds harness during fitting



Ordering information

DESCRIPTION	LENGTH	PRODUCT NUMBER
Wire Spring Type, W1 Small	3.1 in. (8 cm)	52115
Wire Spring Type, W2 Medium	3.7 in. (9.5 cm)	52116
Rubber Pads, for 52115 and 52116		52872

Scissors



5-514

Ordering information

DESCRIPTION	PRODUCT NUMBER
Bandage Scissors, 5.5 in. (140 mm)	5-514
Bandage Scissors, 7.25 in. (184 mm)	5-516
Bandage Scissors, 8 in. (203 mm)	5-550
Bandage Scissors, 8 in. Heavy-Duty (203 mm)	5-568



Tools

US

Hex Screwdriver



DESCRIPTION	PRODUCT NUMBER
Hex Screwdriver, for U-30/G-2 Adjustment Screws, 4 mm Hex	731000120
Hex Screwdriver, for U-30/G-2 Fixing Screws, 3 mm Hex	731000121

Hex Keys

US

SE

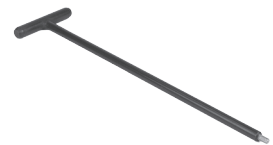

DESCRIPTION	PRODUCT NUMBER
Hex Key, 4 mm	51293
Hex Key, 5 mm	51352
Hex Key, 3 mm	51353
Hex Key, 5mm with 300mm long T-Handle	731000123
Hex Key, 4mm with 300mm long T-Handle	731000122

Torque Screwdriver

SE



DESCRIPTION	PRODUCT NUMBER
BOA Torque Screwdriver, 1.6 Nm	731000153
1/4 in. Bits 4 mm Hex, for BOA Torque Screwdriver	731000155

Torque Wrench

SE



DESCRIPTION	PRODUCT NUMBER
BOA Torque Wrench, 15 Nm	731000150

Scarpas Knife

US



Ordering information

DESCRIPTION	PRODUCT NUMBER
Scarpas Knife, Small for Transtibial	220461
Scarpas Knife, Large for Transfemoral	220460

Surgical Scalpel

US



Ordering information

DESCRIPTION	PRODUCT NUMBER
Scalpel Handle	800050
Blades, Surgical Scalpel, Box (150 Count), #25, 2 in. (51 mm) Long	800060

Pin Wrench

Product Features

- Used for tightening: ALP-Ti Female Pyramid Adapter, 731162120 and ALP-AI Female Pyramid Adapter, 731163187



Ordering information

DESCRIPTION	PRODUCT NUMBER
Pin Wrench DIN1810B-45-50	731000140



Deburring Tool

US



Ordering information

DESCRIPTION	PRODUCT NUMBER
Deburring Tool	220321
Deburring Tool, Blade Only	E-100

Tube Cutter

US

Product Features

- Pocket size pylon cutter with parallel cut control feature
- Cuts all sizes up to 1-1/8 in. (2.9 cm) diameter
- Comes with two extra cutting wheels



220310

60739

Ordering information

DESCRIPTION	PRODUCT NUMBER
Tube Cutter	220310
Heavy-Duty Replacement Wheel	220311
Heavy-Duty Replacement Wheel, for Rigid Cutter	220312
Cutting Guide	60739

Cutting Tool for 30 mm Tubes

US

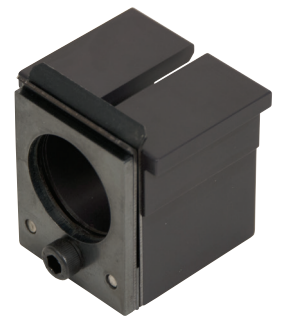

Ordering information

DESCRIPTION	PRODUCT NUMBER
Cutting Tool, for 30 mm Carbon Fiber Tube	731000125

Cast Cutter

US

Product Features

- Manufacturer's descriptive literature available on request
- Oscillating action quickly cuts through plaster
- Trim plastic sockets and Ortholen splints



Ordering information

DESCRIPTION	PRODUCT NUMBER
Cast Cutter Blade, 2.5 in. (64 mm)	226258



Measuring Tapes

US



220331

220328

220329

Ordering information

DESCRIPTION	PRODUCT NUMBER
Measuring Tape (Inch/Metric) Fiberglass Retractable, 60 in. (150 cm)	220328
Measuring Tape (Inch/Metric) PVC-Coated, Fiberglass 60 in. (150 cm)	220329
Disposable Measuring Tape, 10 ft. (300 cm)	220331

Cast Mandrels

US



Ordering information

DESCRIPTION	PRODUCT NUMBER
Aluminum Cast Mandrel, 1.75 × 7.5 in. (44 x 190 mm)	259056
Aluminum Cast Mandrel, 2.38 × 7.5 in. (61 x 190 mm)	259060
Aluminum Cast Mandrel, 2.38 × 10 in. (61 x 254 mm)	259053
Aluminum Cast Mandrel, 2.38 × 15 in. (61 x 381 mm)	259050

Surform™ Files

US

Product Features

- For fast shaping of plaster cast
- Also can be used on wood and plastics



Ordering information

DESCRIPTION	PRODUCT NUMBER
Flat File 10 in. (254 mm), Complete	21-295

REPLACEMENT BLADES

DESCRIPTION	PRODUCT NUMBER
Flat Blade	21-293
Half Round Blade	21-299

Transtibial Length Gauge

US

Product Features

- Measures in inches and metric



Ordering information

DESCRIPTION	PRODUCT NUMBER
Transtibial Gauge	220145

Original AP-ML Gauge

US

Product Features

- Anatomical measuring tool
- Measures in inches and metric



Ordering information

DESCRIPTION	PRODUCT NUMBER
Original AP-ML Gauge, 22 in.	220335

Universal AP-ML Gauge

US

Product Features

- Anatomical measuring tool
- Measures in inches and metric

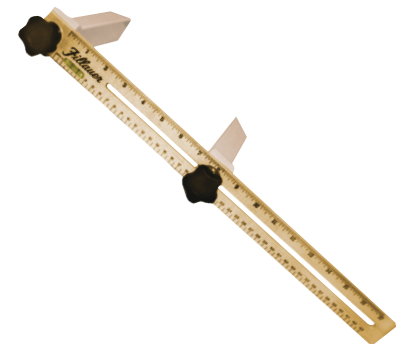

Ordering information

DESCRIPTION	PRODUCT NUMBER
Universal Gauge, with Level, 17 in.	220336



Transfemoral Length Gauge

US

Product Features

- Measures in inches and metric



Ordering information

DESCRIPTION	PRODUCT NUMBER
Transfemoral Length Gauge	220137

Goniometer

US

Product Features

- A combination level and adjustable protractor
- Useful when obtaining measurements that are relative to a horizontal plane



Ordering information

DESCRIPTION	PRODUCT NUMBER
Goniometer	51848

Casting Fixture Gauge

US

Product Features

- For use with the Pelvic casting fixture

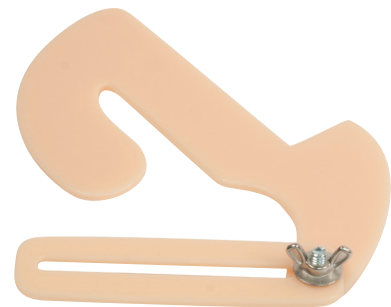

Ordering information

DESCRIPTION	PRODUCT NUMBER
Casting Fixture Gauge	220355

Rounded Blade Spatula

US



Ordering information

DESCRIPTION	PRODUCT NUMBER
Rounded Blade Spatula 0.75 × 4 in. (19 x 102 mm) ,small	220059
Rounded Blade Spatula 1 × 6 in. (25 x 152 mm), large	220063

Hot Mill Gloves

US

Product Features

- Nitrile coated for grip and longer life
- Provides protection against heat up to 250°
- Flexible and strong
- One size fits all



Ordering information

DESCRIPTION	PRODUCT NUMBER
Hot Mill Glove	227008



Materials

Specification symbols

SE Manufactured in Sweden

US Manufactured in USA

Censoft

SE

Specifications

Density: 200 kg/cubic meter

Shore: 00=74

Product Features

- Excellent for use in soft sockets and insoles
- Made of EVA with a blend of 6% rubber
- Good compression memory
- Closed cell material that prevents moisture absorption
- Color: Beige
- Forming temperature: 266 - 320 °F (130 - 160° C)

Ordering information

DESCRIPTION	TIME IN OVEN	PRODUCT NUMBER
35 x 51 x 0.12 in. (900 x 1300 x 3 mm)	1 - 2 min.	637900003
35 x 51 x 0.28 in. (900 x 1300 x 7 mm)	3 - 4 min.	637900007
35 x 51 x 0.55 in. (900 x 1300 x 14 mm)	6 - 8 min.	637900014



Cenpol

SE

Specifications

Density: 30 kg/cubic meter

Shore: 00=44

Product Features

- Suitable for orthoses padding and the build-up of BK Cosmesis
- Made of EVA
- Closed cell material that prevents moisture absorption
- Color: beige
- Forming temperature: 266 - 320 °F (130 - 160° C)

Ordering information

DESCRIPTION	TIME IN OVEN	PRODUCT NUMBER
39 x 39 x 0.12 in. (1000 x 1000 x 3 mm)	25 sec.	637100003
39 x 39 x 0.19 in. (1000 x 1000 x 5 mm)	30 sec.	637100005
39 x 39 x 0.39 in. (1000 x 1000 x 10 mm)	2 min.	637100010
39 x 39 x 0.59 in. (1000 x 1000 x 15 mm)	4 min.	637100015
39 x 39 x 0.78 in. (1000 x 1000 x 20 mm)	6 min.	637100020
39 x 39 x 1.0 in. (1000 x 1000 x 25 mm)	8 min.	637100025





Thermo Foam 4E/ Firm Foam



Product Features

- Closed cell material that prevents moisture absorption
- Thermo foam: hardness shore 00 - 58
- Firm Foam: hardness shore 00 - 88 is considerably harder and suitable for the tongue on braces
- Forming temperature 300°- 356°F (150° - 180°C)
- Color: White

Ordering information

THERMOFOAM

DESCRIPTION	PRODUCT NUMBER
866 x 27.6 x 0.12 in. (22000 x 700 x3 mm)	637700003
591 x 27.6 x 0.24 in. (15000 x 700 x 6 mm)	637700006
36 x 30 x 0.47 in. (920 x 770 x 12 mm)	637770012

FIRMFOAM

DESCRIPTION	PRODUCT NUMBER
295 x 29.9 x 0.12 in. (7500 x 760 x 3 mm)	637760003
47 x 30 x 0.47 in. (1200 x 770 x 12 mm)	637770112



Polypropylene

SE

Product Features

- Copolymer or homopolymer option
- Durable, easy to form thermoplastic
- Forming temperature 356° - 392°F (180° - 200°C)
- Color: Natural



Ordering information

COPOLYMER POLYPROPYLENE

DESCRIPTION	PRODUCT NUMBER
48 x 32 x 0.08 in. (1220 x 800 x 2 mm)	639122002
48 x 32 x 0.12 in. (1220 x 800 x 3 mm)	639122003
48 x 32 x 0.18 in. (1220 x 800 x 4.5 mm)	639122045
48 x 32 x 0.23 in. (1220 x 800 x 6 mm)	639122006
14 x 14 x 0.47 in. (350 x 350 x 12 mm)	639350012
14 x 14 x 0.59 in. (350 x 350 x 15 mm)	639350015
16 x 16 x 0.35 in. (400 x 400 x 9 mm)	639400009
16 x 16 x 0.47 in. (400 x 400 x 12 mm)	639400012
16 x 16 x 0.59 in. (400 x 400 x 15 mm)	639400015

HOMOPOLYMER POLYPROPYLENE

DESCRIPTION	PRODUCT NUMBER
14 x 14 x 0.47 in. (350 x 350 x 12 mm)	639350112
14 x 14 x 0.59 in. (350 x 350 x 15 mm)	639350115
16 x 16 x 0.47 in. (400 x 400 x 12 mm)	639400112
16 x 16 x 0.59 in. (400 x 400 x 15 mm)	639400115



Thermoflex

SE

Product Features

- For flexible sockets and similar
- Skin friendly transparent thermoplastic that does not shrink
- Durable material that is flexible and easy to form to provide good attachment to the skin and seating comfort
- Forming temperature 300°- 356°F (150° - 180°C)



Ordering information

DESCRIPTION	PRODUCT NUMBER
16 x 16 x 0.23 in. (400 x 400 x 6 mm)	637400006
47 x 32 x 0.23 in. (1200 x 800 x 6 mm)	637120006
16 x 16 x 0.31 in. (400 x 400 x 8 mm), Black	637400308
16 x 16 x 0.35 in. (400 x 400 x 9 mm)	637400009
47 x 32 x 0.35 in. (1200 x 800 x 9 mm)	637120009
16 x 16 x 0.39 in. (400 x 400 x 10 mm), Black	637400310
16 x 16 x 0.47 in. (400 x 400 x 12 mm)	637400012
47 x 32 x 0.47 in. (1200 x 800 x 12 mm)	637120012
16 x 16 x 0.47 in. (400 x 400 x 12 mm), Black	637400312

Thermoflex with Silicone

SE

Product Features

- For flexible sockets and similar
- Skin friendly thermoplastic that does not shrink
- Forming temperature 300°- 356°F (150° - 180°C)
- Durable material that is flexible and easy to form to provide good attachment to the skin and seating comfort
- Stays white at working condition
- Low friction



Ordering information

DESCRIPTION	PRODUCT NUMBER
16 x 16 x 0.23 in. (400 x 400 x 6 mm)	637400206
47 x 32 x 0.23 in. (1200 x 800 x 6 mm)	637120206
16 x 16 x 0.35 in. (400 x 400 x 9 mm)	637400209
47 x 32 x 0.35 in. (1200 x 800 x 9 mm)	637120209
16 x 16 x 0.47 in. (400 x 400 x 12 mm)	637400212
47 x 32 x 0.47 in. (1200 x 800 x 12 mm)	637120212

Cleani-Stump Antiseptic Wipe

SE

Product Features

- Developed for use on the sensitive skin of residual limbs and can also be used to disinfect the inside of sockets
- Contains an effective alcohol and lactic acid antiseptic which reduce the amount of bacteria and some viruses on the skin for up to 16 hours
- In addition to the anti-bacterial ingredients found in Cleani-Stump, a special emollient has been added to smoothen and protect skin, helping to prevent breakdown in sensitive areas



Ordering information

DESCRIPTION	PRODUCT NUMBER
Cleani-Stump Antiseptic Wipe case (case of 40 consumer boxes, 2000 total pieces)	631020000
Cleani-Stump Antiseptic Wipe (1 consumer box, 50 wipes pieces)	631020001

Isolation Bags

SE

Product Features

- The isolation bags is made of high quality natural latex rubber with a stretchability of 700%.



Ordering information

DESCRIPTION	PRODUCT NUMBER
X-small, 1.9 x 6.3 in. (50 x 160 mm) 10 per package	615100500
Small, 3.1 x 10.6 in. (80 x 270 mm) 10 per package	615100400
Medium, 3.3 x 11 in. (85 x 280 mm) 10 per package	615100300
Large, 4.3 x 12.2 in. (110 x 310 mm) 10 per package	615100200
X-large, 4.9 x 13.8 in. (125 x 350 mm) 10 per package	615100100
XX-large, 5.5 x 15.7 in. (140 x 400 mm) 10 per package	615100050



PVA Bags and Film

SE

Product Features

- Prefabricated PVA bags made of polyvinyl alcohol film
- Manufactured with a narrow, consistent seam
- 20 pieces per box



Ordering information

PVA BAGS

DESCRIPTION	PRODUCT NUMBER
4 in. (102 x 10 x 5 cm)	631100004
6 in. (102 x 15 x 5 cm)	631100006
8 in. (102 x 20 x 5 cm)	631100008
10 in. (102 x 25 x 5 cm)	631100010
12 in. (102 x 30 x 5 cm)	631100012

PVA FILM

DESCRIPTION	PRODUCT NUMBER
150 ft x 3.3 ft x 0.003 in. (45.7 m x 100 cm x 0.08 mm)	631100050

Alginate Impression Powder

SE

Product Features

- Ideal for casting hands, feet or reproducing sockets
- Easily dissolved in water



Ordering information

DESCRIPTION	PRODUCT NUMBER
Box 13.2 lbs. (6 kg)	633110610
Plastic Bucket 4.4 lbs. (2 kg)	633110020

PolyCar-C Sheets

US

Product Features

- High performance reinforcing composite
- Easy to mold
- High carbon content
- Thermobonds to polypropylene, copolymer and metal

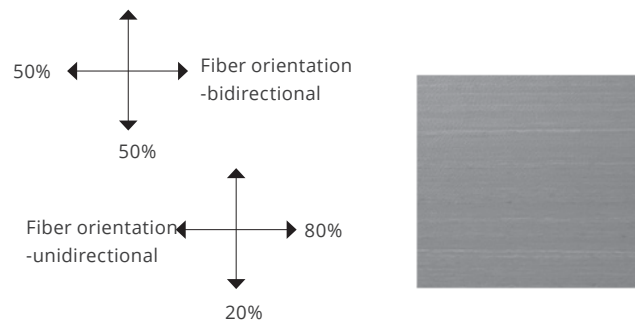

Ordering information

DESCRIPTION	PRODUCT NUMBER
12 X 12 X 0.06 In. (300 X 300 X 1.5 Mm), Bidirectional Fiber Orientation	076608
12 X 24 X 0.06 In. (300 X 600 X 1.5 Mm), Bidirectional Fiber Orientation	076610
12 X 12 X 0.09 In. (300 X 300 X 2.3 Mm), Bidirectional Fiber Orientation	076612
12 X 24 X 0.09 In. (300 X 600 X 2.3 Mm), Bidirectional Fiber Orientation	076614
12 X 12 X 0.125 In. (300 X 300 X 3 Mm), Bidirectional Fiber Orientation	076616
12 X 24 X 0.125 In. (300 X 600 X 3 Mm), Bidirectional Fiber Orientation	076618
12 X 18 X 0.125 In. (300 X 450 X 3 Mm), Unidirectional Fiber Orientation	076620
12 X 36 X 0.125 In. (300 X 900 X 3 Mm), Unidirectional Fiber Orientation	076622

Silicone

SE

Ordering information

DESCRIPTION	PRODUCT NUMBER
Silicone Rubber A 1.25 Kg + B 0.13 kg	632010125
Silicone Oil 1.0 Kg	632020010
Stabilizer for Filler 0.1 Kg	632030001
Silicone Adhesive 90 MI	632040090
Color For Silicone Rubber 0.1 kg	632050001





Transforming Silicone Putty

SE

Product Features

- 1 kg - 500 g component A and 500 g component B
- Mixing ratio: 1:1
- Hardness shore A - 35



Ordering information

DESCRIPTION	PRODUCT NUMBER
1 kg Transforming Silicone Putty (500 g component A and 500 g component B)	632060010

Polyester Stockinette - Lamination Tube

SE

Product Features

- Made of 100% polyester
- Very strong and flexible, does not need to be combined with other materials to reach sufficient strength
- 22 yd. (20 m) per role



Ordering information

DESCRIPTION	WIDTH	PRODUCT NUMBER
Lamination Tube	1.2 in. (30 mm)	636203003
Lamination Tube	2.4 in. (60 mm)	636206005
Lamination Tube	3.1 in. (80 mm)	636208005
Lamination Tube	3.9 in. (100 mm)	636210010

Elastic Stockinette Tube, 7% Lycra

SE

Product Features

- Made of 93% cotton and 7% lycra
- Excellent for casting patients
- 22 yd. (20 m) per role



Ordering information

DESCRIPTION	WIDTH	PRODUCT NUMBER
Elastic Tube	1.6 in. (40 mm)	636304020
Elastic Tube	2.4 in. (60 mm)	636306020
Elastic Tube	3.1 in. (80 mm)	636308020
Elastic Tube	4.3 in. (110 mm)	636311020



Elastic Stockinette Tube, 12,5% Lycra

SE

Product Features

- Made of 87,5% cotton and 12,5% lycra
- Soft, with powerful compression
- Excellent for use under orthoses
- 22 yd. (20 m) per role



Ordering information

DESCRIPTION	WIDTH	PRODUCT NUMBER
Elastic Stockinette	1.6 in. (40 mm)	636404020
Elastic Stockinette	2.4 in. (60 mm)	636406020
Elastic Stockinette	3.1 in. (80 mm)	636408020
Elastic Stockinette	4.3 in. (110 mm)	636411020

Cotton Stockinette

SE

Product Features

- Made of 100% cotton
- Excellent for use under orthosis, casting patients, or for donning prosthesis
- 22 yd. (20 m) per role



Ordering information

DESCRIPTION	WIDTH	PRODUCT NUMBER
Cotton Stockinette	1.6 in. (40 mm)	636504020
Cotton Stockinette	2.4 in. (60 mm)	636506020
Cotton Stockinette	3.1 in. (80 mm)	636508020
Cotton Stockinette	4.3 in. (110 mm)	636511020

Dacron Tape

US

Product Features

- Durable tape has “web” type of construction to prevent stretching
- 25 yd. (22.5 m) per role
- Available in white, black and beige



Ordering information

DESCRIPTION	WIDTH	PRODUCT NUMBER - WHITE	PRODUCT NUMBER - BEIGE	PRODUCT NUMBER - BLACK
Dacron Tape	0.5 in. (13 mm)	212167	212242	212243
Dacron Tape	0.75 in. (19 mm)	212183	212252	-
Dacron Tape	1 in. (25 mm)	212209	212245	212246
Dacron Tape	1.5 in. (38 mm)	212225	212247	212248
Dacron Tape	2 in. (51 mm)	212241	212249	-

Casting Socks

US

Ordering information

Sold per dozen

DESCRIPTION	PRODUCT NUMBER
Casting Balloon, Large, 25 pack	199076
Casting Balloon, Medium, 25 pack	199084
Casting Balloon, Small, 10 pack	199092

Comfort Casting Socks

US

Ordering information

Sold in packages of 6

DESCRIPTION	PRODUCT NUMBER
Below Knee application	63600006





Transfer Paper

US

Product Features

- Different transfer papers available for different products

Ordering information

DESCRIPTION	PRODUCT NUMBER
A. Butterflies	999101
B. Jungle animals	999102
C. Camouflage	999103
D. USA flag	999022
E. Planes, cars & trucks	999125
F. Leopard	999120
G. Solid blue	999021

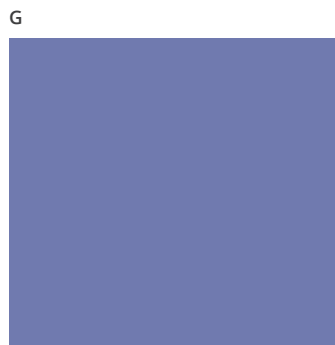
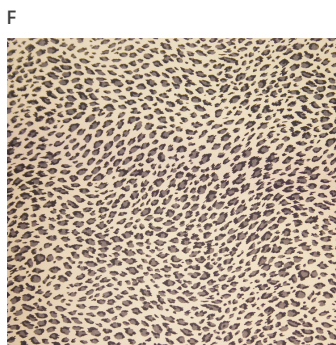
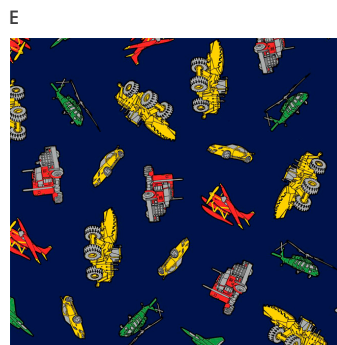
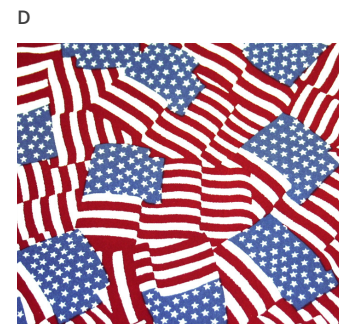
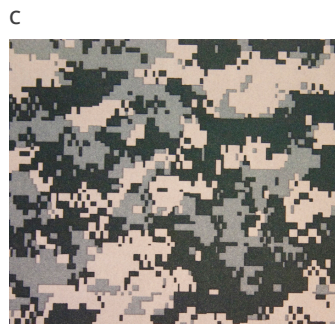

Thermoformable Composite (TFC), Sheets

SE

Product Features

- Unidirectional - Maximal strength in one direction and are good for bars, insoles and strengthening
- Bi-directional - The same strength from 0° and 90° direction and good for difficult shapes like the heel
- Sheet size: 39.4 x 23.6 in. (1000 x 600 mm)



Ordering information

COMFIL® THERMOFORMABLE COMPOSITE UNIDIRECTIONAL

DESCRIPTION	USAGE	THICKNESS	PRODUCT NUMBER
Unidirectional Carbon	Bars and other rigid parts	0.08 in. (2.0 mm)	700010101
Unidirectional Carbon & Glassfiber	Bars and rigid insole	0.1 in. (2.55 mm)	700010103
Unidirectional Carbon	Reinforcements	0.03 in. (0.7 mm)	700010126

COMFIL® THERMOFORMABLE COMPOSITE BIDIRECTIONAL

DESCRIPTION	USAGE	THICKNESS	PRODUCT NUMBER
Bi-directional Glassfiber	Opening flaps	0.03 in. (0.9 mm)	700010121
Bi-directional Glassfiber	Flexible toe off parts	0.06 in. (1.5 mm)	700010122
Bi-directional Glass-and Carbonfiber	Rigid foot plates	0.06 in. (1.5 mm)	700010123
Bi-directional Carbonfiber	Difficult shapes and strengthening	0.03 in. (0.7 mm)	700010124
Bi-directional Glass-and Carbonfiber	Rigid foot plates	0.08 in. (2.1 mm)	700010125
Bi-directional Carbonfiber	Difficult shapes and strengthening	0.02 in. (0.5 mm)	700010127
Bi-directional Glassfiber, clear	Opening flaps	0.03 in. (0.7 mm)	700010128
Bi-directional LCP	Increased flexibility	0.02 in. (0.6 mm)	700010135

For information about the Thermoformable Composite material please contact Fillauer



Thermoformable Composite (TFC), Insole

SE

Product Features

- Flexible insoles are 0.06 in. (1.5 mm) thick and are better for shaping double curves, for example around the heel
- Rigid insole is 0.1 in. (2.5 mm) thick and made to be used as a rolling insole for diabetic patients
- Made for shaping single curves and is harder to shape around the heel
- Sold in pairs



Ordering information

COMFIL® INSOLE FLEXIBLE

	EUROPE	US	PRODUCT NUMBER
Size	35 - 37	3.5 - 5	700030121
Size	38 - 40	6 - 7.5	700030122
Size	41 - 43	8 - 9	700030123
Size	44 - 46	10.5 - 12	700030124

COMFIL® INSOLE RIGID

	EUROPE	US	PRODUCT NUMBER
Size	35 - 37	3.5 - 5	700030141
Size	38 - 40	6 - 7.5	700030142
Size	41 - 43	8 - 9	700030143
Size	44 - 46	10.5 - 12	700030144

Bars

SE

Product Features

- We recommend 700020321 and 700020331 for AFO reinforcement
- We recommend 700040420 for matrix seating reinforcement
- Size 23.6 x 0.8 in. (600 x 20 mm)

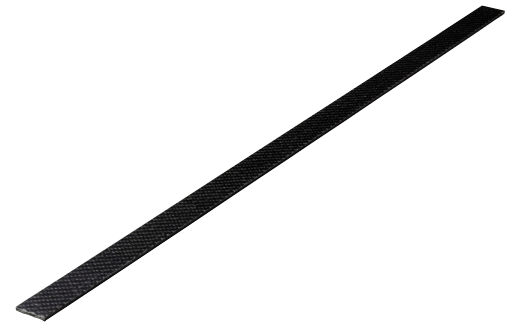

Ordering information

DESCRIPTION	THICKNESS	PRODUCT NUMBER
Unidirectional, Carbon & Glass Fiber	0.1 in. (2.55 mm)	700020321
Unidirectional, Carbon Fiber	0.06 in. (1.6 mm)	700020331
Unidirectional, Carbon Fiber	0.12 in. (3.2 mm)	700040420

TFC Upright Bars & Silicone Forming Sleeve

US

Product Features

- Stronger and lighter than conventional metal uprights
- Thermoformable contouring using heat gun or oven
- Accommodates smaller radii bends
- Increased stiffness and flexibility of carbon composite
- Will not corrode unlike conventional metal uprights
- Uses innovative post pre-preg carbon material
- Optimized attachment plates for conventional metal joints
- Half oval



Ordering information

DESCRIPTION	SIZE	PRODUCT NUMBER
COMFIL® Composite Upright	3/4 x 18.5 in. (19 x 470 mm)	700600
Silicone Forming Sleeve	3/4 x 18.5 in. (19 x 470 mm)	700610
COMFIL® Composite Upright	5/8 x 18.2 in. (16 x 460 mm)	700601
Silicone Forming Sleeve	5/8 x 18.2 in. (16 x 460 mm)	700611
Flat Plate For TFC Upright 3/4 in. Bar		700620
Flat Plate For TFC Upright 5/8 in. Bar		700621
Flat Plate For TFC Upright 3/4 in. Bar Offset Joint		700022



Cotton Stockinette

SE

Product Features

- Good for air evacuation for vacuum
- 3.2 in wide, 22 yd. (20 m) per role



Ordering information

DESCRIPTION	PRODUCT NUMBER
Cotton Stockinette	636508020

Teflon Sheet

SE

Product Features

- Cover in the oven when heating material up
- Dimensions 40 x 40 x 0.01 in. (1000 x 1000 x 0.25 mm)

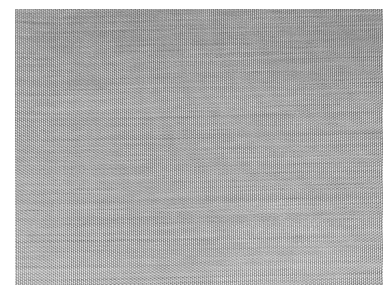

Ordering information

DESCRIPTION	PRODUCT NUMBER
Teflon Sheet	700000010

Silicone Sheet

US



Ordering information

DESCRIPTION	USAGE	THICKNESS	SIZE	PRODUCT NUMBER
Silicone Sheet, Red	Shiny surface	0.02 in. (0.5 mm)	39.4x39.4 in. (1000x1000 mm)	70000011
Silicone Sheet, Transparent, 30 Shore A	Matt surface	0.04 in. (1.0 mm)	39.4x39.4 in. (1000x1000 mm)	70000022
Silicone Sheet, Transparent, High Gloss	Glossy surface	0.03 in. (0.8 mm)	36.2x36.2 in. (920x920mm)	600320

Vacuum Bag material

SE

Product Features

- Roll of 23 ft (10 m)
- Material: Nylon
- Thickness: 0,05 mm
- Width: 457 mm
- Maximum temperature: 246°C**



**: The maximum use temperature is dependent upon duration at maximum temperature and is process specific, we recommends testing prior to use.

Ordering information

DESCRIPTION	SIZE	PRODUCT NUMBER
Vacuum Bag Material, Tube	18 x 0.002 in. (457 x 0.05 mm)	70000012

Tape

SE

Product Features

- High temp. tape for use with TFC material



700000015



700000014

Ordering information

DESCRIPTION	USAGE	SIZE	PRODUCT NUMBER
Sealing Tape for Vacuum Bag	Sealing the vacuum bag	0.12 x 0.5in. x 24.9 ft. (3 x 12 mm x 7.6 m)	700000014
Tape	Fasten the release film to the plaster	1 in. x 108 ft (25 mm x 33 m)	700000015



Silicone Glove

SE

Product Features

- Sold individually
- Colors may vary



Ordering information

DESCRIPTION	PRODUCT NUMBER
TFC Silicone Glove	700070010

Release Film - sheet

SE

Product Features

- Prevent moisture from reaching the carbon fiber
- Size 47.2 x 39.4 in. (1200 x 1000 mm)



Ordering information

DESCRIPTION	THICKNESS	PRODUCT NUMBER
Release Film	0.001 in. (0.025 mm)	700000023

Silicone Bag

SE

Product Features

- For shiny surface



Ordering information

DESCRIPTION	PRODUCT NUMBER
Silicone Bag, small	700000105
Silicone Bag, medium	700000107
Silicone Bag, large	700000109

Index

Accessory Holder for Bench Carver	19	Goniometer	56
Accessory Holder for Floor Carver	16	Grinding Rasps	27
Air Attachment for Floor Carver	16		
Alginate Impression Powder	64	Hex Keys	50
Bar Contouring Device	44	Hex Screwdriver	50
Bars	73	Holding Frames	34
Bench Carver Floor Stand	19	Hot Mill Gloves	57
Bending Irons	48	Isolation Bags	63
Cable Swaging Tool	45	Joint Alignment Tool	47
Cast Cutter	53	Laminating Fixture LJ-100	42
Casting Fixture Gauge	56	Lift Assist Kit for Floor Carver	17
Casting Socks	69	Measuring Tapes	54
Cast Mandrels		Mobile Vacuum Unit	32
	54	Original AP-ML Gauge	55
Catalog symbol legend	8	PDQ BT-4 Infrared Oven	38
Cenpol	59	PDQ Oven Fan Kit	40
Censoft	59	PDQ Oven Gloves	40
Cleani-Stump Antiseptic Wipe	63	PDQ PO-2 Infrared Oven	39
Comfort Casting Socks	69	PDQ Rollabout Oven	37
Contouring Fork and Bench Receptacle	47	Pin Wrench	51
Contouring Irons	48	Pipe Holding Fixtures	44
Cotton Stockinette	68	Pneumatic Sand Drum	22
Cotton Stockinette	74	PolyCar-C Sheets	65
Cutters & Replacement Blades	20	Polyester Stockinette - Lamination Tube	67
Cutting Tool for 30 mm Tubes	52	Polypropylene	61
Dacron Tape	69	Portable Oilless Vacuum Pump	33
Deburring Tool	52	Prosthetic Bench Vise	45
Drape Forming Adapters	34	PVA Bags and Film	64
Drill Attachments 1/2"-13 Thread	20	Release Film - sheet	76
Drill Press Fixture	46	Returns, Adjustments, and Credits	7
Dual Purpose Expansion Arbors	26	Rounded Blade Spatula	
Durrplex	60		57
Dust Collection Hose Kit for 2100L	15	Router Adapters	27
Dust Collector for Bench Carver	19	Rubber Sand Cones	23
Dust Collector for Floor Carver	15	Sand Drum	22
Elastic Stockinette Tube, 7% Lycra	67	Scarpas Knife	51
Elastic Stockinette Tube, 12,5% Lycra	68	Scissors	49
Expansion Arbors	25	Shaft Foam Arbors	21
Fillauer Product Warranty	6	Silicone	65



Silicone Bag	76	Universal AP-ML Gauge	55
Silicone Glove	76	Urethane and Felt Arbors	22
Silicone Sheet	75	Vacuum Bag material	75
Soft Foam Shaper	21	Vacuum Control Assembly	33
Spring Clamps	49	Vertical Fabricating Fixture, VFJ-100	43
Stirrup Bender	46	Yates Clamp	49
Surform™ Files	54		
Surgical Scalpel	51		
Surgical Tubing	42		
Tape	75		
Tapered Felt Arbor/ Core	24		
Teflon Sheet	74		
TFC Upright Bars & Silicone Forming Sleeve	73		
Thermoflex	62		
Thermoflex with Silicone	62		
Thermo Foam 4E/ Firm Foam	60		
Thermoformable Composite (TFC), Insole	72		
Thermoformable Composite (TFC), Sheets	71		
Tongue Tray	40		
Torque Screwdriver	50		
Torque Wrench	50		
Transfemoral Length Gauge	56		
Transfer Paper	70		
Transforming Silicone Putty	66		
Transtibial Length Gauge	55		
Trautman Arbor 5001	10		
Trautman Coneiak Polishing Arbors	29		
Trautman Double Drum Sander	11		
Trautman Single Speed Bench Carver	18		
Trautman Single Speed Floor Carver	13		
Trautman Tech Station	14		
Trautman Vacuum Stations	35		
Trautman Variable Speed Bench Carver	18		
Trautman Variable Speed Floor Carver	12		
Tube Cutter	52		
Tycro Polishing Arbor	28		
Universal Alignment Fixture	46		





